

Chapter 2

Formulation of FEM for One-Dimensional Problems

2.1 One-Dimensional Model DE and a Typical Piecewise Continuous FE Solution

To demonstrate the basic principles of FEM let's use the following 1D, steady advection-diffusion equation

$$u \frac{dT}{dx} - k \frac{d^2T}{dx^2} = f \quad \text{in } \Omega \quad (2.1)$$

where u and k are the known, constant velocity and diffusivity, respectively. $f(x)$ is the known source function and $T(x)$ is the scalar unknown. This 2nd order ODE should be supported by two boundary conditions (BCs) provided at the two ends of the 1D domain. At a boundary either the value of the unknown or the value of its first derivative or an equation involving both the unknown and the first derivative is specified.

In a FE solution we divide the problem domain into a finite number of elements and try to obtain polynomial type approximate solutions over each element. The simplest polynomial we can use to approximate the variation of the solution over an element is a linear polynomial, as shown in Figure 2.1. The FE solution shown in this figure makes use of a mesh with NE many first order (2 node) elements. The mesh also has $NN = NE + 1$ nodes. This approximate solution is said to be C^0 continuous, i.e. only the 0th order derivative (the solution itself) is continuous across element interfaces, but not higher order derivatives.

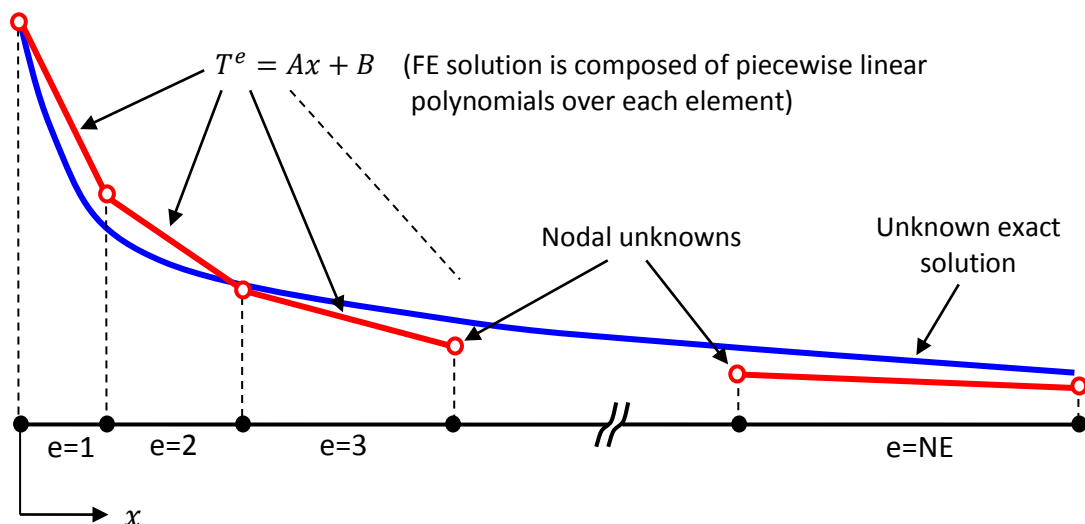

Figure 2.1 Typical C^0 continuous approximate solution over a 1D domain with NE linear elements

In a FE solution the task is to find the linear approximate solutions, T^e 's over each element, which requires the calculation of unknown T values at the nodes of the mesh, shown with red circles in Figure 2.1. In total we need to determine NN many T values and for this we need to derive NN linear algebraic equations.

2.2 Method of Weighted Residuals (MWR) and the Weak Form of a DE

The DE given in equation (2.1), together with proper BCs, is known as the strong form of the problem. FEM is a weighted residual type numerical method and it makes use of the weak form of the problem. There are a number of different ways that one can use to derive the weak form of a DE. For solid mechanics problems the preferred technique makes use of variational principles such as the minimization of total potential energy. However, for the DEs that govern thermofluidic transport problems we prefer to use the Method of Weighted Residuals (MWR) to obtain the weak form, as explained below.

Residual of a DE is obtained by collecting all the terms on one side of the equation. Residual of the DE given in equation (2.1) is

$$R(x) = u \frac{dT}{dx} - k \frac{d^2T}{dx^2} - f \quad (2.2)$$

By definition exact solution of a DE will make its residual zero at all points of the problem domain. However, the residual will not in general vanish when an approximate solution is substituted in it. The basic principle in weighted residual methods is to minimize the residual in a weighted integral sense as follows

$$\int_{\Omega} w(x) R(x) dx = 0 \quad (2.3)$$

Substituting equation (2.2) into (2.3) one gets

$$\int_{\Omega} \left(wu \frac{dT}{dx} - wk \frac{d^2T}{dx^2} - wf \right) dx = 0 \quad (2.4)$$

which is known as the weighted residual statement of the DE. $w(x)$ are user selected weight (or test) functions. The idea is to select as many different weight functions as necessary to obtain the required NN linear algebraic equations. In theory as NN goes to infinity, the integral of equation (2.4) will be zero for infinitely many different weight function selections, which can only be true if the residual itself vanishes over the problem domain, i.e. as NN goes to infinity, approximate solution approaches to the exact solution.

As mentioned previously the approximate solution shown in Figure 2.1 is only C^0 continuous. In theory it is possible to use higher order continuous approximations such as C^1 , but they are not preferred because of the complicated mathematics they require, especially for 2D and 3D problems. However, if we use a C^0 continuous solution in the above weighted residual statement, the second order derivatives that appear in the diffusion term can not be evaluated properly. In order to be able to work with a C^0 continuous approximate solution, we need to lower the differentiation requirements of the unknown in the weighted residual statement. This is done by applying integration by parts to the second term (diffusion term) of equation (2.4), as shown below

$$\int_{\Omega} -wk \frac{d^2T}{dx^2} dx = \int_{\Omega} k \frac{dw}{dx} \frac{dT}{dx} dx - \int_{\Gamma} wk \frac{dT}{dx} n_x d\Gamma \quad (2.5)$$

As a by-product of integration by parts, the last term of equation (2.5), called boundary integral is obtained. This term is evaluated at the boundaries (Γ) of the problem domain (Ω), where n_x is the x component of the unit outward normal of the boundary. For the problem sketched in Figure 2.1 n_x is equal to -1 and 1 at the left and right boundaries of the problem domain, respectively. As seen from the above equation, integration by parts lowers the differentiation order of the unknown T from 2 to 1, and increases the differentiation order of the weight function w from 0 to 1. Note that integration by parts is not applied to the advection term, which only contains first order derivative of T .

If we substitute equation (2.5) into equation (2.4) we get

$$\int_{\Omega} \left(wu \frac{dT}{dx} + k \frac{dw}{dx} \frac{dT}{dx} \right) dx = \int_{\Omega} wf dx + \int_{\Gamma} wk \frac{dT}{dx} n_x d\Gamma \quad (2.6)$$

At this point it is worth to emphasize once again that the terms on the left hand side of the above equation now includes only first order derivatives of the unknown. This is called the weak form of the problem due to this lower differentiability requirements compared to the original weighted residual statement. To summarize, weak form allows us to work with C^0 continuous approximate solutions.

2.3 Primary and Secondary Variables and Boundary Conditions

The boundary term on the right hand side of equation (2.6) is an important part of the FE formulation. It can be used to identify the primary and secondary variables of a problem. To do this we separate the boundary term into two parts; the first part contains the weight function and possibly its derivatives and the second part contains the dependent variable (unknown) and possibly its derivatives. In our case part 1 includes only w . The dependent variable of the problem T , expressed in the same form as this first part of the boundary term is called the primary variable (PV). For this problem PV is T . Part 2 includes $k \frac{dT}{dx} n_x$, which is the secondary variable (SV) of the problem. Secondary variables always have important physical meanings such as the amount of heat flux that passes through the boundary in a heat transfer problem.

After identifying the PV and SV of the problem, now we can discuss about possible BCs of our DE. If the PV is provided at a boundary of the problem it is called an Essential (Dirichlet) BC (EBC). Providing the SV at a boundary is known as Natural (Neumann) BC (NBC). Finally mixed (or Robin) BC specifies a combination of PV and SV at a boundary. For the problem we are working on possible EBCs and NBCs are

$$\text{Essential BC (EBC) : } T = T_0 \quad (2.7a)$$

$$\text{Natural BC (NBC) : } k \frac{dT}{dx} n_x = q_0 \quad (2.7b)$$

$$\text{Mixed BC (MBC) : } k \frac{dT}{dx} n_x = \alpha T + \beta \quad (2.7c)$$

Transferring a given DE into a weak form not only enables us to use C^0 continuous solutions, but also automatically includes NBCs and MBCs into the formulation. This is a unique property of FEM, which is not shared with other numerical methods such as Finite Difference or Finite Volume Method. For a given EBC, the nodal unknown at that boundary is not actually an unknown. Therefore the number of

discrete nodal unknowns that needs to be calculated reduces by 1. For a given NBC or MBC SV inside the boundary integral is simply replaced by the specified q_0 value as shown below

$$\begin{aligned} \text{Natural BC (NBC)} &\rightarrow \int_{\Gamma} wk \frac{dT}{dx} n_x d\Gamma = \int_{\Gamma} wq_0 d\Gamma \\ \text{Mixed BC (MBC)} &\rightarrow \int_{\Gamma} wk \frac{dT}{dx} n_x d\Gamma = \int_{\Gamma} w(\alpha T + \beta) d\Gamma \end{aligned}$$

For a 1D problem boundary of the problem domain consists of only two discrete points, i.e. the right end and the left nodes of the FE mesh. Therefore for a 1D problem, we actually do not need to evaluate integrals as shown above; instead we simply need to evaluate the integrand at the boundary node. As we'll see later for 2D problems boundaries will be line segments and the above boundary integrals become line integrals, and for 3D they become area integrals.

2.4 Constructing an Approximate Solution using Shape Functions

Now that we have the weak form available we can substitute the desired approximate solution into it. C^0 continuous approximate solution that is shown in Figure 2.1 can be expressed as

$$T_{app}(x) = \sum_{j=1}^{NN} T_j S_j(x) \quad (2.8)$$

where T_{app} is the approximate solution that we are after. NN is the number of nodes in the FE mesh. T_j 's are the nodal unknown values that we are going to calculate at the end of the FE solution and S_j 's are the shape (basis) functions that are used to construct the approximate solution. Figure 2.2 shows these details for a 1D mesh.

As seen from Figure 2.2 it is possible to associate each shape function with one node of the FE mesh. Shape functions are said to have compact support, i.e. they are nonzero only over the elements which touch the node with which they are associated, everywhere else they are equal to zero. They also possess the following important Kronecker-delta property

$$S_j(x_i) = \delta_{ij} = \begin{cases} 1 & \text{if } i = j \\ 0 & \text{if } i \neq j \end{cases} \quad (2.9)$$

which tells that the j^{th} shape function has a value of 1 at the j^{th} node of the mesh and it is equal to zero at all other nodes.

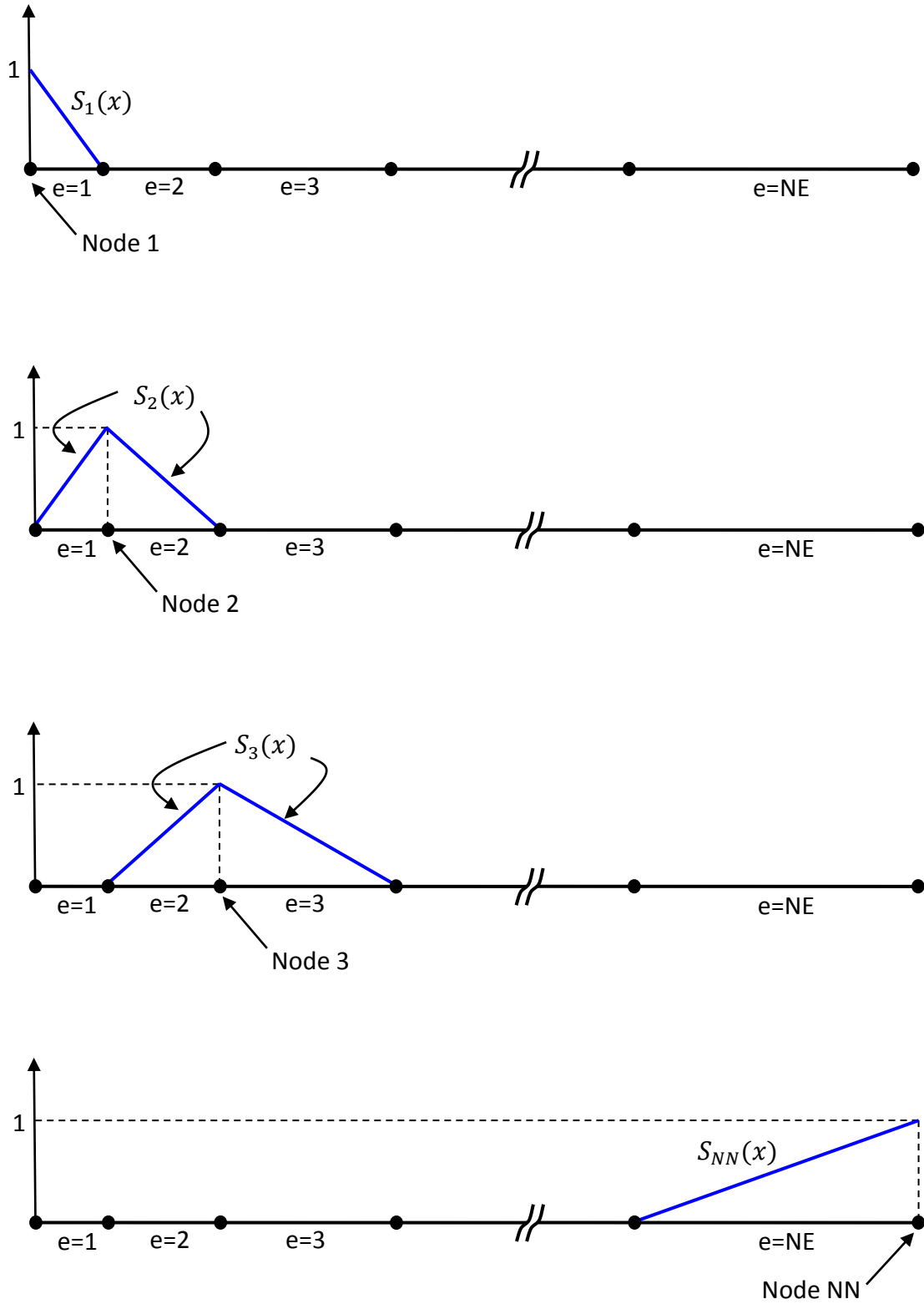

Figure 2.2 Shape (basis) functions for a 1D FE mesh of linear elements.

Now we can substitute the approximate solution T_{app} given in equation (2.8) into the weak form given in equation (2.6) to get

$$\int_{\Omega} \left[wu \left(\sum_{j=1}^{NN} T_j \frac{dS_j}{dx} \right) + k \frac{dw}{dx} \left(\sum_{j=1}^{NN} T_j \frac{dS_j}{dx} \right) \right] dx = \int_{\Omega} wf dx + \int_{\Gamma} w(SV) d\Gamma \quad (2.10)$$

where SV is used as a shortcut for the secondary variable of the problem. After selecting a weight function, evaluating the above integrals and using the given BCs, the above equation provides just one linear, algebraic equation for NN unknowns of the problem. In order to obtain all the necessary NN equations we need to select NN many different weight functions, and there is no unique way of selecting them.

2.5 Galerkin FEM (GFEM) and the Global System

In the most commonly used variation of FEM known as Galerkin FEM (GFEM) weight functions of equation (2.10) are selected to be the same as the shape functions shown in figure 2.2. That is to get the i^{th} equation we use

$$\text{In GFEM: } w(x) = S_i(x) \quad (2.11)$$

With this selection equation (2.10) can be expressed as the following i^{th} equation of a set of NN equations

$$\int_{\Omega} \left[S_i u \left(\sum_{j=1}^{NN} T_j \frac{dS_j}{dx} \right) + k \frac{dS_i}{dx} \left(\sum_{j=1}^{NN} T_j \frac{dS_j}{dx} \right) \right] dx = \int_{\Omega} S_i f dx + \int_{\Gamma} S_i(SV) d\Gamma \quad i = 1, 2, \dots, NN \quad (2.12)$$

It is possible to take the summation sign outside the integral and get

$$\sum_{j=1}^{NN} \left[\int_{\Omega} \left(S_i u \frac{dS_j}{dx} + k \frac{dS_i}{dx} \frac{dS_j}{dx} \right) dx \right] T_j = \int_{\Omega} S_i f dx + \int_{\Gamma} S_i(SV) d\Gamma \quad i = 1, 2, \dots, NN \quad (2.13)$$

To further simplify the equation we can use the following compact matrix notation

$$[K]\{T\} = \{F\} + \{B\} \quad (2.14)$$

which is known as the global equation system. $\{T\}$ is the vector of nodal unknowns with NN entries. $[K]$ is the global square stiffness matrix of size $NN \times NN$ with entries given below

$$K_{ij} = \int_{\Omega} \left(S_i u \frac{dS_j}{dx} + k \frac{dS_i}{dx} \frac{dS_j}{dx} \right) dx \quad (2.15)$$

$\{F\}$ and $\{B\}$ are the global force vector and boundary integral vector of size $NN \times 1$ with entries given as follows

$$F_i = \int_{\Omega} S_i f dx \quad \text{and} \quad B_i = \int_{\Gamma} S_i (SV) d\Gamma \quad (2.16)$$

$[K]$ and $\{F\}$ integrals are evaluated over the whole problem domain, whereas the boundary integral is evaluated only at the problem boundaries.

2.6 Elemental Systems

Based on the fact that shape functions that appear in $[K]$ and $\{F\}$ integrals have non-zero values only over a small portion of the problem domain, most FEM computer codes evaluate these integrals as a sum of separate integrals over individual elements.

$$[K] = \sum_{e=1}^{NE} [K^e] \quad \text{and} \quad \{F\} = \sum_{e=1}^{NE} \{F^e\} \quad (2.17)$$

where $[K^e]$ and $\{F^e\}$ are elemental stiffness matrices and elemental force vectors. A similar elemental integral summation procedure can also be applied for the calculation of $\{B\}$, however for a 1D problem that is discussed here, problem boundaries are simply two nodes, and therefore no integral evaluation is actually necessary at the boundaries.

Let's first concentrate on the calculation of elemental stiffness matrices, given below

$$K_{ij}^e = \int_{\Omega^e} \left(S_i u \frac{dS_j}{dx} + k \frac{dS_i}{dx} \frac{dS_j}{dx} \right) dx \quad (2.18)$$

The first thing to notice is that $[K^e]$ for all elements are $NN \times NN$ square matrices, i.e. both i and j indices go from 1 to NN . However, as seen in Figure 2.2, only two shape functions have non-zero values over each element, and there will be contribution to $[K^e]$ only from these two shape functions. In other words many of the entries of the $NN \times NN$ matrix will be zero. To give an example consider Figure 2.3 that shows the non-zero shape functions over an arbitrary element e located between nodes M and N.

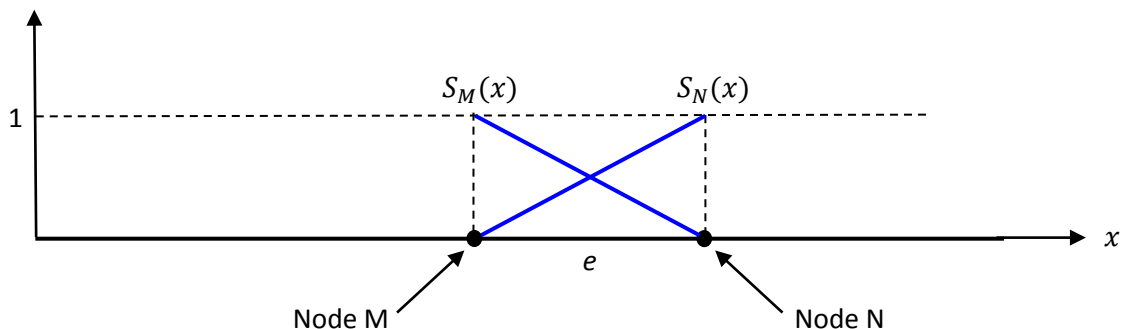

Figure 2.3 Non-zero shape functions over a linear element

The stiffness matrix $[K^e]$ for this element will look like the following

$$\begin{array}{c}
 \text{Column M} \quad \quad \quad \text{Column N} \\
 \begin{array}{c} \text{Row M} \\ \text{Row N} \end{array} \rightarrow \begin{bmatrix} \ddots & & & & & & \ddots \\ & 0 & 0 & 0 & 0 & 0 & \\ & 0 & 0 & 0 & 0 & 0 & \\ & \vdots & \vdots & \begin{bmatrix} A & B \\ C & D \end{bmatrix} & \vdots & \vdots & \\ & 0 & 0 & 0 & 0 & 0 & \\ & 0 & 0 & 0 & 0 & 0 & \\ & \vdots & \vdots & \vdots & \vdots & \vdots & \ddots \end{bmatrix}
 \end{array}$$

As seen above two non-zero shape functions over element e will create only 4 non-zero entries in $[K^e]$. Of course in a computer code we are not going to spend time and memory to calculate and store obviously zero entries of $[K^e]$. Instead we will calculate each $[K^e]$ to be a small 2x2 matrix. But these small 2x2 elemental matrices cannot simply be added to obtain the global stiffness matrix of size $NN \times NN$. Instead small matrices should be assembled into the appropriate locations of the global stiffness matrix. This assembly process, which will be discussed in detail later, is an important part of a FE solution.

Similar to the stiffness matrix calculation explained above, force vector calculation is also done for each element separately. Global force vector $\{F\}$ of size $NN \times 1$ is then obtained by the assembly of elemental force vectors.

At this point it is logical to start working with a local node numbering scheme as shown below

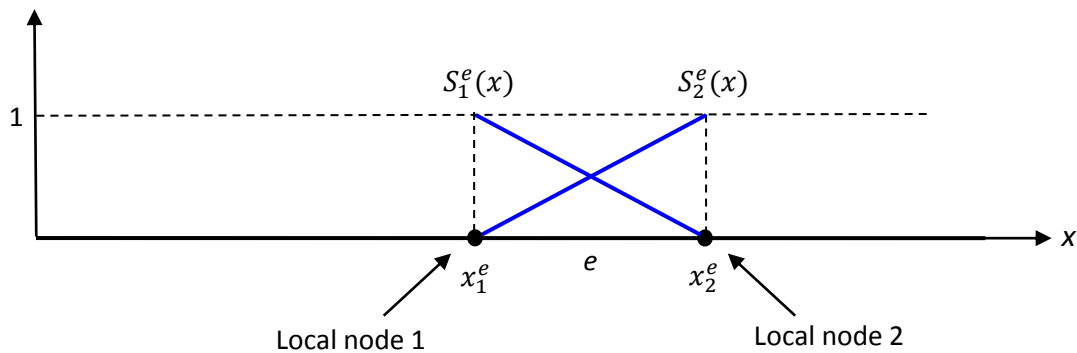

Figure 2.4 Local node numbering of a 1D, linear element

2.7 Gauss Quadrature Integration – Concepts of Master Element and Jacobian

In order to have a general purpose FE solver that can be used for the solution of different DEs without changing the source code, $[K^e]$ integrals are almost always evaluated numerically. Although MATLAB, the programming tool that we'll use in this course, can perform symbolic integration, numerical integration is more flexible and it is much faster. Gauss Quadrature (GQ) is the most

preferred numerical integration technique, in which integrals are evaluated between special limits of -1 and 1.

$$\int_{-1}^1 f(\xi) d\xi = \sum_{k=1}^{NGP} f(\xi_k) W_k \quad (2.19)$$

where ξ_k are special GQ points in the interval [-1, 1] and W_k are the corresponding GQ weights. NGP is the number of GQ points that we want to use. GQ points and weights for different NGP values are tabulated in several numerical methods and FEM books. Values up to NGP=3 are given in Table 2.1.

Table 2.1 One dimensional Gauss Quadrature points and weights

NGP	ξ_k	W_k
1	0	2
2	$-\sqrt{1/3}$	1
	$\sqrt{1/3}$	1
3	$-\sqrt{3/5}$	5/9
	0	8/9
	$\sqrt{3/5}$	5/9

Limits of $[K^e]$ integral are $x = x_1^e$ and $x = x_2^e$, which are simply the coordinates of the two end points of the element, as seen in Figure 2.4. In order to be able to evaluate $[K^e]$ integral using GQ, limits of the integral should be from changed to be -1 and 1, which requires a change of variable. This brings the concept of using a master element in evaluating elemental integrals.

Figure 2.5 shows the 1D master element with two nonzero shape functions on it. Master element uses a special new variable, ξ , which changes between -1 and 1 over an element.

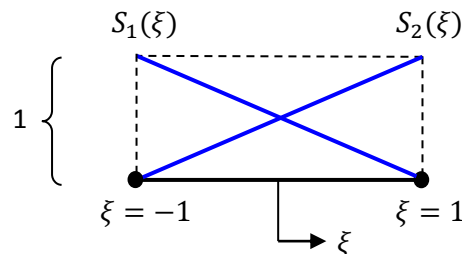

Figure 2.5 One-dimensional, linear master element and the ξ coordinate system

Using the Kronecker-delta property of the shape functions, we can write them in terms of the master element coordinate ξ as follows

$$S_1 = \frac{1}{2}(1 - \xi) \quad \text{and} \quad S_2 = \frac{1}{2}(1 + \xi) \quad (2.20)$$

In order to be able to evaluate $[K^e]$ integrals we need a relation between the global x coordinate and the newly introduced ξ coordinate. For the element e of Figure 2.6, located between points $x = x_1^e$ and $x = x_2^e$, with a length of h^e the linear relation between x and ξ is

$$x = \frac{h^e}{2}\xi + \frac{x_1^e + x_2^e}{2} \quad (2.21)$$

where h^e is the length of element e given by

$$h^e = x_2^e - x_1^e \quad (2.22)$$

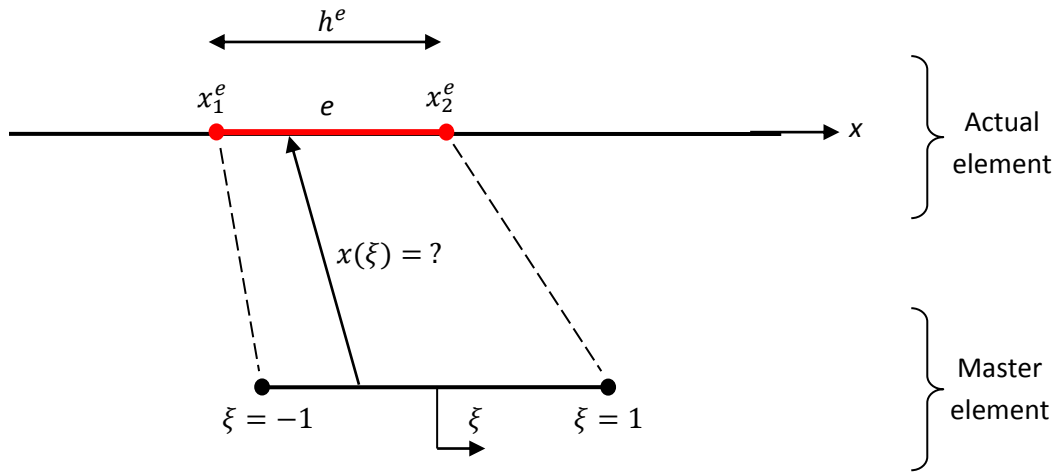

Figure 2.6 Mapping between the global x coordinate and the master element coordinate ξ .

Now we can write the elemental $[K^e]$ integral given in equation (2.18) using the ξ coordinate and new limits suitable for GQ integration

$$K_{ij}^e = \int_{-1}^1 \left(S_i u \frac{dS_j}{d\xi} \frac{d\xi}{dx} + k \frac{dS_i}{d\xi} \frac{d\xi}{dx} \frac{dS_j}{d\xi} \frac{d\xi}{dx} \right) \frac{dx}{d\xi} d\xi \quad (2.23)$$

Defining an important variable in FE formulation, the Jacobian, as

$$J^e = \frac{dx}{d\xi} = \frac{h^e}{2} \quad (2.24)$$

elemental stiffness matrix calculation becomes

$$K_{ij}^e = \int_{-1}^1 \left(S_i u \frac{dS_j}{d\xi} \frac{1}{J^e} + k \frac{dS_i}{d\xi} \frac{1}{J^e} \frac{dS_j}{d\xi} \frac{1}{J^e} \right) J^e d\xi \quad (2.25)$$

This is the final form that is ready to be calculated using GQ integration in a computer code.

Calculation of elemental force vectors can be follows a similar approach and results in the following equation

$$F_i^e = \int_{-1}^1 S_i f J^e d\xi \quad (2.26)$$

Note that if the functions u, k and f of the DE are functions of x , they should first be written as a function of ξ using equation (2.21).

2.8 Assembly Process

As a final detail, let's discuss the assembly process that is already mentioned previously. After calculating small 2x2 elemental stiffness matrices and small 2x1 elemental force vectors, they should be assembled into the proper locations of the global system of equations. To do this we'll first generate a local to global node mapping. For the following mesh of 4 linear elements with shown global node numbers

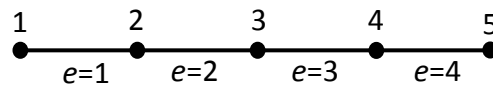

local to global node mapping matrix that will be used in the assembly process is

$$LtoG = \begin{bmatrix} 1 & 2 \\ 2 & 3 \\ 3 & 4 \\ 4 & 5 \end{bmatrix} \leftarrow \text{Second element is in between nodes 2 and 3}$$

There are NE many rows in LtoG matrix. i^{th} row contains the global node numbers of the i^{th} element. For example the second row tells that first and second local nodes of the second element correspond to the 2nd and 3rd global nodes. Note that for the above mesh we assumed that for all elements left and right nodes are the first and second local nodes, respectively.

Having the LtoG matrix, now we can perform the assembly process using the following assembly rule

- Assemble K_{ij}^e entry of an elemental stiffness matrix into K_{IJ} entry of the global stiffness matrix,
- Assemble F_i^e entry of an elemental force vector into F_I entry of the global force vector,
- Assemble B_i^e entry of an elemental boundary integral vector into B_I entry of the global boundary integral vector,

where

$$I = LtoG(e, i) \quad , \quad J = LtoG(e, j) \quad (2.27)$$

This assembly process will provide the following global stiffness matrix, force vector and the boundary integral vector for the 5 node mesh given above. Different colors used below correspond to the contribution of different elements.

$$[K] = \begin{bmatrix} K_{11}^1 & K_{12}^1 & 0 & 0 & 0 \\ K_{21}^1 & K_{22}^1 + K_{11}^2 & K_{12}^2 & 0 & 0 \\ 0 & K_{21}^2 & K_{22}^2 + K_{11}^3 & K_{12}^3 & 0 \\ 0 & 0 & K_{21}^3 & K_{22}^3 + K_{11}^4 & K_{12}^4 \\ 0 & 0 & 0 & K_{21}^4 & K_{22}^4 \end{bmatrix}, \quad \{F\} = \begin{Bmatrix} F_1^1 \\ F_2^1 + F_1^2 \\ F_2^2 + F_1^3 \\ F_2^3 + F_1^4 \\ F_2^4 \end{Bmatrix}$$

$$\{B\} = \begin{Bmatrix} B_1^1 \\ B_2^1 + B_1^2 \\ B_2^2 + B_1^3 \\ B_2^3 + B_1^4 \\ B_2^4 \end{Bmatrix} = \begin{Bmatrix} B_1^1 \\ 0 \\ 0 \\ 0 \\ B_2^4 \end{Bmatrix}$$

For the 5 node mesh, global equation system given in equation (2.14) is

$$\begin{bmatrix} K_{11} & K_{12} & K_{13} & K_{14} & K_{15} \\ K_{21} & K_{22} & K_{23} & K_{24} & K_{25} \\ K_{31} & K_{32} & K_{33} & K_{34} & K_{35} \\ K_{41} & K_{42} & K_{43} & K_{44} & K_{45} \\ K_{51} & K_{52} & K_{53} & K_{54} & K_{55} \end{bmatrix} \begin{Bmatrix} T_1 \\ T_2 \\ T_3 \\ T_4 \\ T_5 \end{Bmatrix} = \begin{Bmatrix} F_1 \\ F_2 \\ F_3 \\ F_4 \\ F_5 \end{Bmatrix} + \begin{Bmatrix} B_1 \\ B_2 \\ B_3 \\ B_4 \\ B_5 \end{Bmatrix} \quad (2.28)$$

2.9 Boundary Conditions

First let's consider the boundary integral vector $\{B\}$ of equation (2.28). Boundary integral term of the weak formulation should be evaluated only at the boundary nodes of the problem domain, not at the inner nodes. Therefore for our sample 5 node mesh, inner node entries of $\{B\}$ should be zero, i.e. $B_2 = B_3 = B_4 = 0$ and the global system becomes

$$\begin{bmatrix} K_{11} & K_{12} & K_{13} & K_{14} & K_{15} \\ K_{21} & K_{22} & K_{23} & K_{24} & K_{25} \\ K_{31} & K_{32} & K_{33} & K_{34} & K_{35} \\ K_{41} & K_{42} & K_{43} & K_{44} & K_{45} \\ K_{51} & K_{52} & K_{53} & K_{54} & K_{55} \end{bmatrix} \begin{Bmatrix} T_1 \\ T_2 \\ T_3 \\ T_4 \\ T_5 \end{Bmatrix} = \begin{Bmatrix} F_1 \\ F_2 \\ F_3 \\ F_4 \\ F_5 \end{Bmatrix} + \begin{Bmatrix} B_1 \\ 0 \\ 0 \\ 0 \\ B_5 \end{Bmatrix} \quad (2.29)$$

Remaining entries of $\{B\}$ are evaluated using equation (2.16) as follows

$$B_1 = [S_1(SV)]|_{node\ 1} = (SV)|_{node\ 1}$$

$$B_5 = [S_5(SV)]|_{node\ 5} = (SV)|_{node\ 5} \quad (2.30)$$

S_1 and S_5 are the global shape functions similar to the ones given in Figure 2.2 and they are equal to 1 at nodes 1 and 5, respectively. Therefore nonzero B values of the global system are nothing but the SV's at the boundary nodes.

For the 5 node sample mesh we are working on nodes 1 and 5 are boundary nodes. Either an Essential, Natural or mixed BC should be provided at these nodes. If an EBC is given at a boundary

node then the PV (T value) given there is known and the corresponding SV (B value) is not known. If a NBC is given then the B value at that boundary node is known but the corresponding T value is not known. For a mixed BC neither T nor B is known, but instead a relation between them is known.

To demonstrate how an EBC is implemented let's assume that at node 1 the unknown T is given to be a value of T_{left} . T_1 of equation (2.29) is no longer an unknown and we can get rid of the first equation of the global system. When we delete the first equation we should also delete the first column of $[K]$ and we should modify the force vector on the right accordingly. This process is known as reduction, and for the case we are studying it results in the following reduced 4x4 global system.

$$\begin{bmatrix} K_{22} & K_{23} & K_{24} & K_{25} \\ K_{32} & K_{33} & K_{34} & K_{35} \\ K_{42} & K_{43} & K_{44} & K_{45} \\ K_{52} & K_{53} & K_{54} & K_{55} \end{bmatrix} \begin{Bmatrix} T_2 \\ T_3 \\ T_4 \\ T_5 \end{Bmatrix} = \begin{Bmatrix} F_2 - K_{21}T_{left} \\ F_3 - K_{31}T_{left} \\ F_4 - K_{41}T_{left} \\ F_5 - K_{51}T_{left} \end{Bmatrix} + \begin{Bmatrix} 0 \\ 0 \\ 0 \\ B_5 \end{Bmatrix} \quad (2.31)$$

To demonstrate how a NBC is implemented let's assume that at node 5 NBC is specified. This means that the value of B_5 is given and we simply use this known value in equation (2.31). Implementation of NBC is very simple.

If a mixed type BC is given at node 5 instead of NBC, the implementation becomes a little bit more involved. As given in equation (2.7c) a mixed type BC at node 5 can be generalized as follows

$$B_5 = \alpha T_5 + \beta \quad (2.32)$$

where α and β are known values. We substitute this relation in equation (2.31) to get

$$\begin{bmatrix} K_{22} & K_{23} & K_{24} & K_{25} \\ K_{32} & K_{33} & K_{34} & K_{35} \\ K_{42} & K_{43} & K_{44} & K_{45} \\ K_{52} & K_{53} & K_{54} & K_{55} \end{bmatrix} \begin{Bmatrix} T_2 \\ T_3 \\ T_4 \\ T_5 \end{Bmatrix} = \begin{Bmatrix} F_2 - K_{21}T_{left} \\ F_3 - K_{31}T_{left} \\ F_4 - K_{41}T_{left} \\ F_5 - K_{51}T_{left} \end{Bmatrix} + \begin{Bmatrix} 0 \\ 0 \\ 0 \\ \alpha T_5 + \beta \end{Bmatrix} \quad (2.33)$$

αT_5 term on the right hand side of the equation should be transferred to the left hand side, which will modify the diagonal entry of $[K]$ for the last equation as follows

$$\begin{bmatrix} K_{22} & K_{23} & K_{24} & K_{25} \\ K_{32} & K_{33} & K_{34} & K_{35} \\ K_{42} & K_{43} & K_{44} & K_{45} \\ K_{52} & K_{53} & K_{54} & K_{55} - \alpha \end{bmatrix} \begin{Bmatrix} T_2 \\ T_3 \\ T_4 \\ T_5 \end{Bmatrix} = \begin{Bmatrix} F_2 - K_{21}T_{left} \\ F_3 - K_{31}T_{left} \\ F_4 - K_{41}T_{left} \\ F_5 - K_{51}T_{left} \end{Bmatrix} + \begin{Bmatrix} 0 \\ 0 \\ 0 \\ \beta \end{Bmatrix} \quad (2.34)$$

Now this is a solvable set with 4 equations and 4 unknowns.

2.10 First 1D Solution

We'll try to obtain an approximate solution of the following problem

$$u \frac{dT}{dx} - k \frac{d^2T}{dx^2} = f \quad \text{in} \quad 0 \leq x \leq 1$$

with $u = 3$, $k = 1$, $f = 1$. The DE is supported by the following two essential boundary conditions (EBCs)

$$T(0) = 0 \quad \text{and} \quad T(1) = 0$$

using Galerkin FEM (GFEM) on a mesh of 5 equi-sized elements as shown below

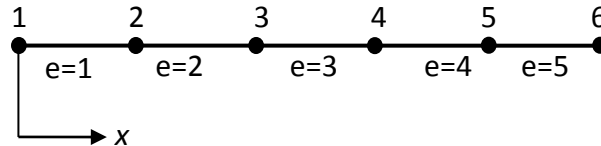

Elemental stiffness matrices can be evaluated using the following equation as derived previously

$$K_{ij}^e = \int_{-1}^1 \left(S_i u \frac{dS_j}{d\xi} \frac{1}{J^e} + k \frac{dS_i}{d\xi} \frac{1}{J^e} \frac{dS_j}{d\xi} \frac{1}{J^e} \right) J^e d\xi$$

Each element has the length of $h^e = 0.2$ and the same Jacobian of $J^e = \frac{h^e}{2} = 0.1$. u and k are given as constants. Therefore $[K^e]$ will be the same for all elements. Using previously derived shape functions of

$$S_1 = \frac{1}{2}(1 - \xi) \quad \text{and} \quad S_2 = \frac{1}{2}(1 + \xi),$$

four entries of the 2x2 $[K^e]$ matrix can be calculated as (no need to use GQ integration for this exercise)

$$K_{11}^e = \int_{-1}^1 \left(\frac{1}{2}(1 - \xi)(3) \left(-\frac{1}{2}\right) (10) + (1) \left(-\frac{1}{2}\right) (10) \left(-\frac{1}{2}\right) (10) \right) (0.1) d\xi = \frac{7}{2}$$

$$K_{12}^e = \int_{-1}^1 \left(\frac{1}{2}(1 - \xi)(3) \left(\frac{1}{2}\right) (10) + (1) \left(-\frac{1}{2}\right) (10) \left(\frac{1}{2}\right) (10) \right) (0.1) d\xi = -\frac{7}{2}$$

$$K_{21}^e = \int_{-1}^1 \left(\frac{1}{2}(1 + \xi)(3) \left(-\frac{1}{2}\right) (10) + (1) \left(\frac{1}{2}\right) (10) \left(-\frac{1}{2}\right) (10) \right) (0.1) d\xi = -\frac{13}{2}$$

$$K_{22}^e = \int_{-1}^1 \left(\frac{1}{2}(1 + \xi)(3) \left(\frac{1}{2}\right) (10) + (1) \left(\frac{1}{2}\right) (10) \left(\frac{1}{2}\right) (10) \right) (0.1) d\xi = \frac{13}{2}$$

Therefore for all elements

$$K^e = \begin{bmatrix} 7/2 & -7/2 \\ -13/2 & 13/2 \end{bmatrix}$$

Remember that the general form of the elemental force vector is

$$F_i^e = \int_{-1}^1 S_{if} J d\xi$$

Since function f is constant and the same for each element, elemental force vectors will also be the same for all elements. Their components can be evaluated as

$$F_1^e = \int_{-1}^1 \frac{1}{2}(1 - \xi) (1) (0.1) d\xi = \frac{1}{10}$$

$$F_2^e = \int_{-1}^1 \frac{1}{2}(1 + \xi) (1) (0.1) d\xi = \frac{1}{10}$$

Combining these two entries we get

$$F^e = \begin{Bmatrix} 1/10 \\ 1/10 \end{Bmatrix}$$

Local to global mapping of the mesh is given by

$$LtoG = \begin{bmatrix} 1 & 2 \\ 2 & 3 \\ 3 & 4 \\ 4 & 5 \\ 5 & 6 \end{bmatrix}$$

Using the assembly rule global stiffness matrix and global force vector is obtained as follows

$$K = \begin{bmatrix} \frac{7}{2} & -\frac{7}{2} & 0 & 0 & 0 & 0 \\ -\frac{13}{2} & \frac{13}{2} + \frac{7}{2} & -\frac{7}{2} & 0 & 0 & 0 \\ 0 & -\frac{13}{2} & \frac{13}{2} + \frac{7}{2} & -\frac{7}{2} & 0 & 0 \\ 0 & 0 & -\frac{13}{2} & \frac{13}{2} + \frac{7}{2} & -\frac{7}{2} & 0 \\ 0 & 0 & 0 & -\frac{13}{2} & \frac{13}{2} + \frac{7}{2} & -\frac{7}{2} \\ 0 & 0 & 0 & 0 & -\frac{13}{2} & \frac{13}{2} \end{bmatrix} \quad F = \begin{Bmatrix} \frac{1}{10} \\ \frac{1}{10} + \frac{1}{10} \\ \frac{1}{10} + \frac{1}{10} \\ \frac{1}{10} + \frac{1}{10} \\ \frac{1}{10} + \frac{1}{10} \\ \frac{1}{10} \end{Bmatrix}$$

And the global system of equations becomes

$$\begin{bmatrix} \frac{7}{2} & -\frac{7}{2} & 0 & 0 & 0 & 0 \\ -\frac{13}{2} & \frac{13}{2} + \frac{7}{2} & -\frac{7}{2} & 0 & 0 & 0 \\ 0 & -\frac{13}{2} & \frac{13}{2} + \frac{7}{2} & -\frac{7}{2} & 0 & 0 \\ 0 & 0 & -\frac{13}{2} & \frac{13}{2} + \frac{7}{2} & -\frac{7}{2} & 0 \\ 0 & 0 & 0 & -\frac{13}{2} & \frac{13}{2} + \frac{7}{2} & -\frac{7}{2} \\ 0 & 0 & 0 & 0 & -\frac{13}{2} & \frac{13}{2} \end{bmatrix} \begin{Bmatrix} T_1 \\ T_2 \\ T_3 \\ T_4 \\ T_5 \\ T_6 \end{Bmatrix} = \begin{Bmatrix} \frac{1}{10} \\ \frac{1}{10} + \frac{1}{10} \\ \frac{1}{10} + \frac{1}{10} \\ \frac{1}{10} + \frac{1}{10} \\ \frac{1}{10} + \frac{1}{10} \\ \frac{1}{10} \end{Bmatrix} + \begin{Bmatrix} B_1 \\ 0 \\ 0 \\ 0 \\ 0 \\ B_6 \end{Bmatrix}$$

Due to the provided EBCs at $x = 0$ and $x = 1$, T_1 and T_6 are actually known and we can perform reduction as explained in the previous section to remove the first and last equation resulting in the following 4 equations for 4 unknowns

$$\begin{bmatrix} \frac{13}{2} + \frac{7}{2} & -\frac{7}{2} & 0 & 0 \\ -\frac{13}{2} & \frac{13}{2} + \frac{7}{2} & -\frac{7}{2} & 0 \\ 0 & -\frac{13}{2} & \frac{13}{2} + \frac{7}{2} & -\frac{7}{2} \\ 0 & 0 & -\frac{13}{2} & \frac{13}{2} + \frac{7}{2} \end{bmatrix} \begin{Bmatrix} T_2 \\ T_3 \\ T_4 \\ T_5 \end{Bmatrix} = \begin{Bmatrix} \frac{1}{10} + \frac{1}{10} \\ \frac{1}{10} + \frac{1}{10} \\ \frac{1}{10} + \frac{1}{10} \\ \frac{1}{10} + \frac{1}{10} \end{Bmatrix} + \begin{Bmatrix} 0 \\ 0 \\ 0 \\ 0 \end{Bmatrix}$$

Solving this system we get the necessary nodal unknowns as

$$\begin{Bmatrix} T_2 \\ T_3 \\ T_4 \\ T_5 \end{Bmatrix} = \begin{Bmatrix} 0.0531 \\ 0.0946 \\ 0.1146 \\ 0.0945 \end{Bmatrix}$$

The following figure compares the GFEM solution with the exact one, which can be found using MATLAB's `dsolve` command.

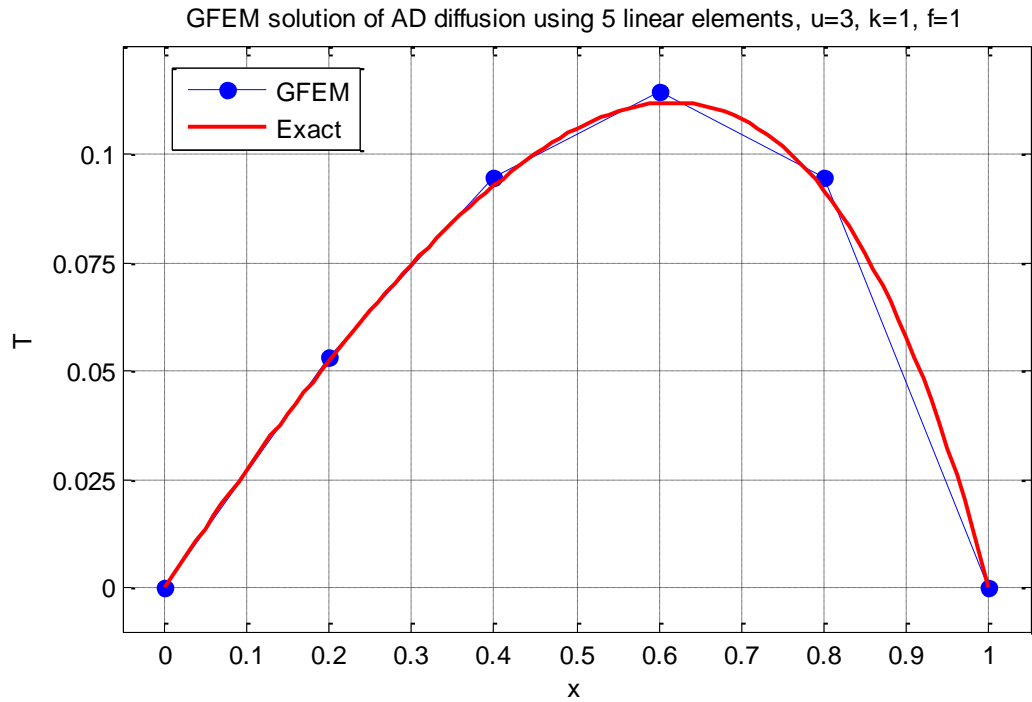

2.11 Second 1D Solution

Solve the same problem but change the BC at $x = 1$ as follows

$$\left. \frac{dT}{dx} \right|_{x=1} = -1$$

This BC change will not bring any changes to the elemental system calculation or to the assembly process. Therefore the same global system, given below, will be obtained.

$$\begin{bmatrix} \frac{7}{2} & -\frac{7}{2} & 0 & 0 & 0 & 0 \\ -\frac{13}{2} & 10 & -\frac{7}{2} & 0 & 0 & 0 \\ 0 & -\frac{13}{2} & 10 & -\frac{7}{2} & 0 & 0 \\ 0 & 0 & -\frac{13}{2} & 10 & -\frac{7}{2} & 0 \\ 0 & 0 & 0 & -\frac{13}{2} & 10 & -\frac{7}{2} \\ 0 & 0 & 0 & 0 & -\frac{13}{2} & \frac{13}{2} \end{bmatrix} \begin{Bmatrix} T_1 \\ T_2 \\ T_3 \\ T_4 \\ T_5 \\ T_6 \end{Bmatrix} = \begin{Bmatrix} 1/10 \\ 1/5 \\ 1/5 \\ 1/5 \\ 1/5 \\ 1/10 \end{Bmatrix} + \begin{Bmatrix} B_1 \\ 0 \\ 0 \\ 0 \\ 0 \\ B_6 \end{Bmatrix}$$

At $x = 0$, there is the same EBC with a value of zero. Reduction can be applied to the above system to get rid of the first equation. Resulting system will be

$$\begin{bmatrix} 10 & -\frac{7}{2} & 0 & 0 & 0 \\ -\frac{13}{2} & 10 & -\frac{7}{2} & 0 & 0 \\ 0 & -\frac{13}{2} & 10 & -\frac{7}{2} & 0 \\ 0 & 0 & -\frac{13}{2} & 10 & -\frac{7}{2} \\ 0 & 0 & 0 & -\frac{13}{2} & \frac{13}{2} \end{bmatrix} \begin{Bmatrix} T_2 \\ T_3 \\ T_4 \\ T_5 \\ T_6 \end{Bmatrix} = \begin{Bmatrix} 1/5 \\ 1/5 \\ 1/5 \\ 1/5 \\ 1/10 \end{Bmatrix} + \begin{Bmatrix} 0 \\ 0 \\ 0 \\ 0 \\ B_6 \end{Bmatrix}$$

NBC given at $x = 1$ should now be used. B_6 of the last equation is the SV at $x = 1$, which is equal to $\left. \frac{dT}{dx} \right|_{x=1}$ and this is specified as -1. Therefore we can simply replace B_6 with the given value of -1.

$$\begin{bmatrix} 10 & -\frac{7}{2} & 0 & 0 & 0 \\ -\frac{13}{2} & 10 & -\frac{7}{2} & 0 & 0 \\ 0 & -\frac{13}{2} & 10 & -\frac{7}{2} & 0 \\ 0 & 0 & -\frac{13}{2} & 10 & -\frac{7}{2} \\ 0 & 0 & 0 & -\frac{13}{2} & \frac{13}{2} \end{bmatrix} \begin{Bmatrix} T_2 \\ T_3 \\ T_4 \\ T_5 \\ T_6 \end{Bmatrix} = \begin{Bmatrix} 1/5 \\ 1/5 \\ 1/5 \\ 1/5 \\ 1/10 \end{Bmatrix} + \begin{Bmatrix} 0 \\ 0 \\ 0 \\ 0 \\ -1 \end{Bmatrix}$$

Now this is a solvable system with 5 equations and 5 unknowns. The solution gives the following nodal values

$$\begin{Bmatrix} T_2 \\ T_3 \\ T_4 \\ T_5 \\ T_6 \end{Bmatrix} = \begin{Bmatrix} 0.0494 \\ 0.0841 \\ 0.0913 \\ 0.0475 \\ -0.0910 \end{Bmatrix}$$

Comparison of exact and approximate solutions is given below

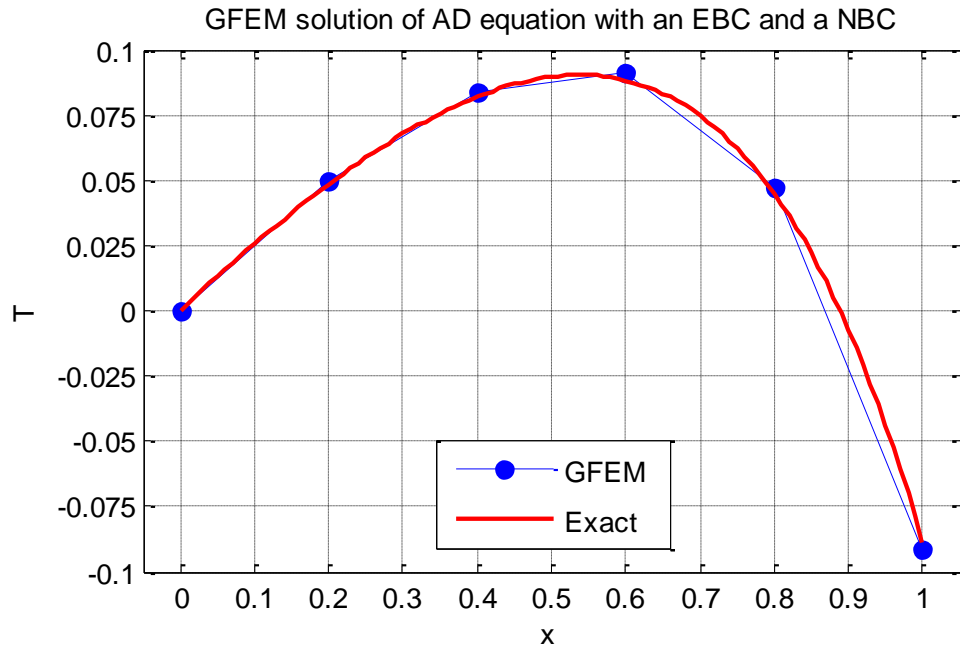

This solution is also as good as the previous one. Note that at the left boundary, where EBC is specified, the nodal value is exact, however at the right boundary where NBC is specified this is not the case.

2.12 Third 1D Solution

Solve the same problem but change the BC at $x = 1$ as follows

$$\left(T + 2 \frac{dT}{dx}\right)\bigg|_{x=1} = 20$$

Again the 6x6 global system will not change. After applying reduction for the known T_1 we get

$$\begin{bmatrix} 10 & -\frac{7}{2} & 0 & 0 & 0 \\ -\frac{13}{2} & 10 & -\frac{7}{2} & 0 & 0 \\ 0 & -\frac{13}{2} & 10 & -\frac{7}{2} & 0 \\ 0 & 0 & -\frac{13}{2} & 10 & -\frac{7}{2} \\ 0 & 0 & 0 & -\frac{13}{2} & \frac{13}{2} \end{bmatrix} \begin{Bmatrix} T_2 \\ T_3 \\ T_4 \\ T_5 \\ T_6 \end{Bmatrix} = \begin{Bmatrix} 1/5 \\ 1/5 \\ 1/5 \\ 1/5 \\ 1/10 \end{Bmatrix} + \begin{Bmatrix} 0 \\ 0 \\ 0 \\ 0 \\ B_6 \end{Bmatrix}$$

To implement the given mixed BC we first put it into the form given in equation (2.32)

$$\left(\frac{dT}{dx}\right)\bigg|_{x=1} = -0.5 T|_{x=1} + 10$$

where α and β of equation (2.32) becomes -0.5 and 10 , respectively. With these values last equation of the global system can be modified as explained in Section 2.9, resulting in

$$\begin{bmatrix} 10 & -\frac{7}{2} & 0 & 0 & 0 \\ -\frac{13}{2} & 10 & -\frac{7}{2} & 0 & 0 \\ 0 & -\frac{13}{2} & 10 & -\frac{7}{2} & 0 \\ 0 & 0 & -\frac{13}{2} & 10 & -\frac{7}{2} \\ 0 & 0 & 0 & -\frac{13}{2} & \frac{13}{2} - (-0.5) \end{bmatrix} \begin{Bmatrix} T_2 \\ T_3 \\ T_4 \\ T_5 \\ T_6 \end{Bmatrix} = \begin{Bmatrix} 1/5 \\ 1/5 \\ 1/5 \\ 1/5 \\ 1/10 \end{Bmatrix} + \begin{Bmatrix} 0 \\ 0 \\ 0 \\ 0 \\ 10 \end{Bmatrix}$$

Following nodal values are obtained by solving this system

$$\begin{Bmatrix} T_2 \\ T_3 \\ T_4 \\ T_5 \\ T_6 \end{Bmatrix} = \begin{Bmatrix} 0.1727 \\ 0.4362 \\ 0.8684 \\ 1.6141 \\ 2.9416 \end{Bmatrix}$$

Comparison of exact and approximate solutions is given below

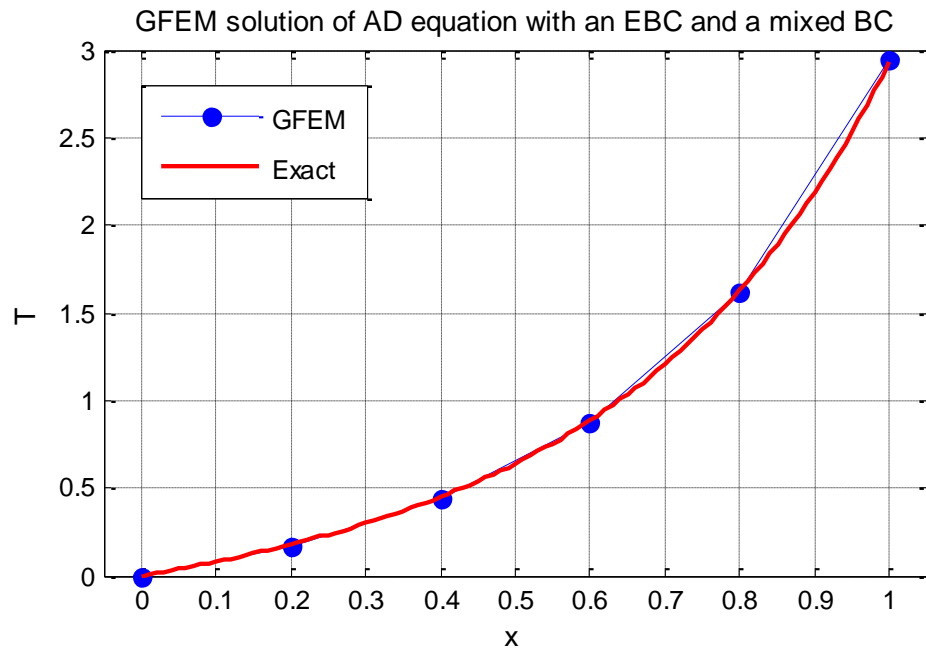

2.13 Higher Order Elements in 1D

Up to now only linear (2 node) elements are mentioned, but it is possible to use higher order elements that are constructed using more than 2 nodes. Figure 2.7 shows a FE mesh of quadratic (3 node) elements and a couple of the shape functions.

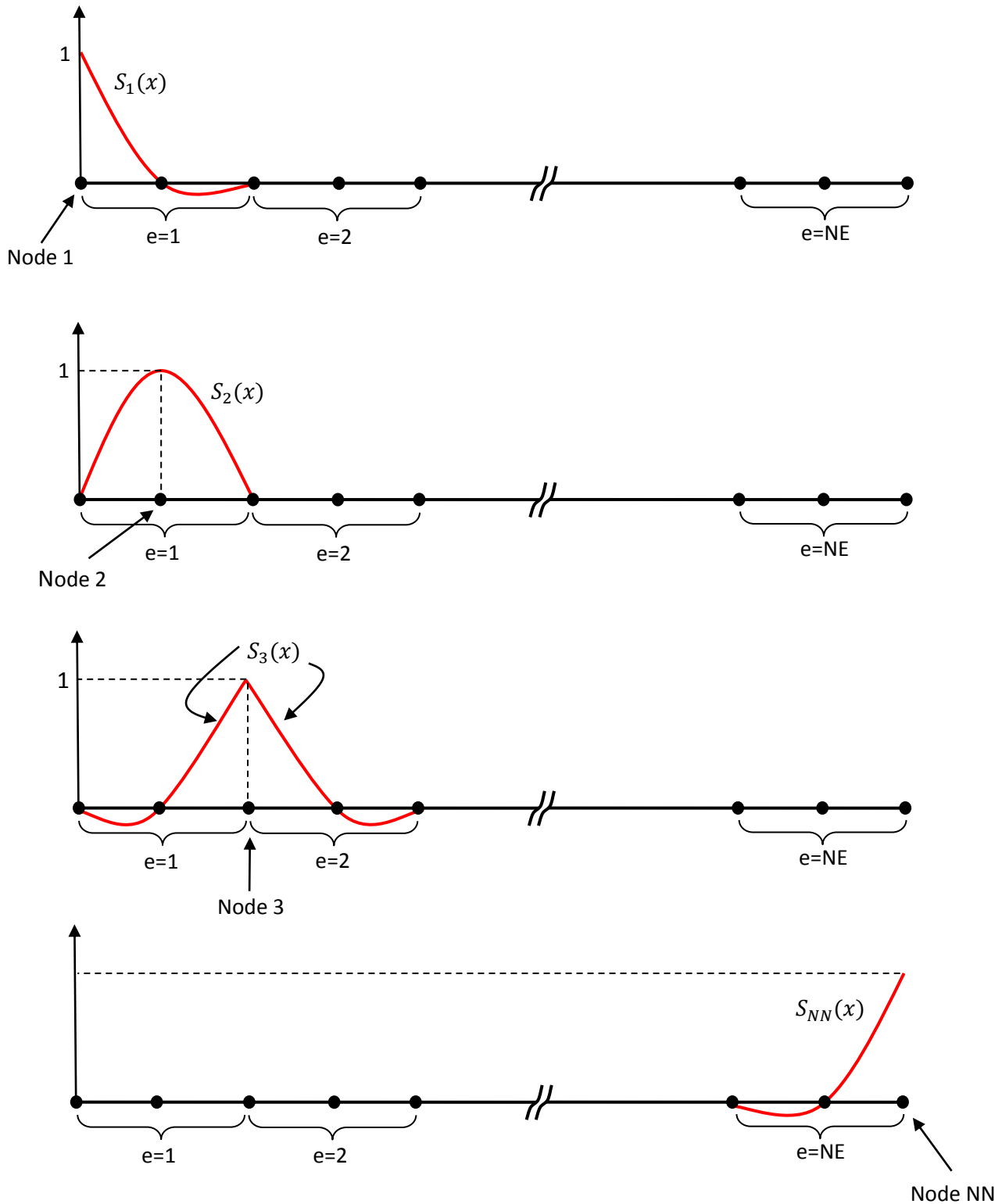

Figure 2.7 Shape functions for a 1D FE mesh of quadratic (3 node) elements

In Figure 2.7 node 2 is an internal node of the first element and the 2nd shape function related to this node is non-zero only on the first element. It has no contribution to any other element. Node 3 is shared by first and second elements and 3rd shape function is non-zero on these two elements.

On each element there are three non-zero shape functions and Figure 2.8 shows them on a master element

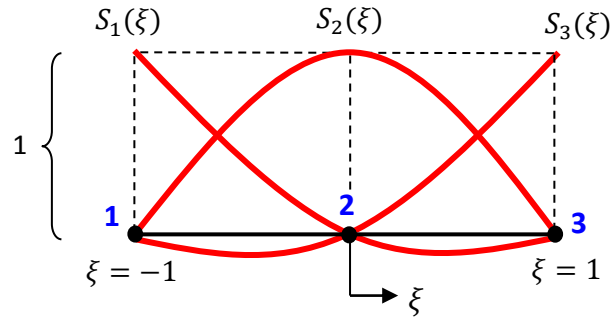

Figure 2.8 One-dimensional, quadratic (3 node) master element

Blue numbers show the local node numbering. Second node is located at the center of the element. This is true not only for the master element, but also for the real elements. Kronecker-delta property of the shape functions can be used to derive them as follows

$$S_1 = \frac{1}{2}\xi(\xi - 1) \quad , \quad S_2 = (1 - \xi^2) \quad \text{and} \quad S_3 = \frac{1}{2}\xi(1 + \xi) \quad (2.28)$$

As demonstrated in the following sample solution, for quadratic elements elemental stiffness matrices are 3x3 matrices and elemental force vectors are 3x1 vectors.

2.14 Fourth 1D Solution

We want to solve the same AD problem that we solved in Section 2.11 (the one with an EBC and a NBC) using the following mesh of 2 equi-sized quadratic elements.

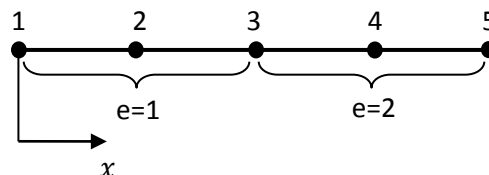

Elemental stiffness matrices can be evaluated using the same equation that we used previously for linear elements

$$K_{ij}^e = \int_{-1}^1 \left(S_i u \frac{dS_j}{d\xi} \frac{1}{J^e} + k \frac{dS_i}{d\xi} \frac{1}{J^e} \frac{dS_j}{d\xi} \frac{1}{J^e} \right) J^e d\xi$$

Both elements has a length of $h^e = 0.5$ and a Jacobian of $J^e = h^e/2 = 1/4$. Similar to the previous solution $[K^e]$ will be the same for both elements. Using the shape functions of quadratic elements, entries of the 3x3 $[K^e]$ can be calculated as

$$K_{11}^e = \int_{-1}^1 \left(\frac{1}{2} \xi(\xi-1)(3) \left(\frac{1}{2} (2\xi-1) \right) (4) + (1) \left(\frac{1}{2} (2\xi-1) \right) (4) \left(\frac{1}{2} (2\xi-1) \right) (4) \right) \left(\frac{1}{4} \right) d\xi = \frac{19}{6}$$

$$K_{12}^e = \int_{-1}^1 \left(\frac{1}{2} \xi(\xi-1)(3)(-2\xi) (4) + (1) \left(\frac{1}{2} (2\xi-1) \right) (4)(-2\xi) (4) \right) \left(\frac{1}{4} \right) d\xi = -\frac{10}{3}$$

$$K_{13}^e = \int_{-1}^1 \left(\frac{1}{2} \xi(\xi-1)(3) \left(\frac{1}{2} (2\xi+1) \right) (4) + (1) \left(\frac{1}{2} (2\xi-1) \right) (4) \left(\frac{1}{2} (2\xi+1) \right) (4) \right) \left(\frac{1}{4} \right) d\xi = \frac{1}{6}$$

$$K_{21}^e = \int_{-1}^1 \left((1-\xi^2)(3) \left(\frac{1}{2} (2\xi-1) \right) (4) + (1) (-2\xi) (4) \left(\frac{1}{2} (2\xi-1) \right) (4) \right) \left(\frac{1}{4} \right) d\xi = -\frac{22}{3}$$

$$K_{22}^e = \int_{-1}^1 \left((1-\xi^2)(3)(-2\xi) (4) + (1) (-2\xi) (4)(-2\xi) (4) \right) \left(\frac{1}{4} \right) d\xi = \frac{32}{3}$$

$$K_{23}^e = \int_{-1}^1 \left((1-\xi^2)(3) \left(\frac{1}{2} (2\xi+1) \right) (4) + (1) (-2\xi) (4) \left(\frac{1}{2} (2\xi+1) \right) (4) \right) \left(\frac{1}{4} \right) d\xi = -\frac{10}{3}$$

$$K_{31}^e = \int_{-1}^1 \left(\frac{1}{2} \xi(\xi+1)(3) \left(\frac{1}{2} (2\xi-1) \right) (4) + (1) \left(\frac{1}{2} (2\xi+1) \right) (4) \left(\frac{1}{2} (2\xi-1) \right) (4) \right) \left(\frac{1}{4} \right) d\xi = \frac{7}{6}$$

$$K_{32}^e = \int_{-1}^1 \left(\frac{1}{2} \xi(\xi+1)(3)(-2\xi) (4) + (1) \left(\frac{1}{2} (2\xi+1) \right) (4)(-2\xi) (4) \right) \left(\frac{1}{4} \right) d\xi = -\frac{22}{3}$$

$$K_{33}^e = \int_{-1}^1 \left(\frac{1}{2} \xi(\xi+1)(3) \left(\frac{1}{2} (2\xi+1) \right) (4) + (1) \left(\frac{1}{2} (2\xi+1) \right) (4) \left(\frac{1}{2} (2\xi+1) \right) (4) \right) \left(\frac{1}{4} \right) d\xi = \frac{37}{6}$$

Therefore for both elements

$$K^e = \begin{bmatrix} 19/6 & -10/3 & 1/6 \\ -22/3 & 32/3 & -10/3 \\ 7/6 & -22/3 & 37/6 \end{bmatrix}$$

Remembering the following general form of the elemental force vector

$$F_i^e = \int_{-1}^1 S_i f J d\xi$$

and noticing that the source function f is constant and the same for each element, elemental force vectors will also be the same for all elements. Its entries can be evaluated as

$$F_1^e = \int_{-1}^1 \frac{1}{2} \xi(\xi - 1) (1) \left(\frac{1}{4}\right) d\xi = \frac{1}{12}$$

$$F_2^e = \int_{-1}^1 (1 - \xi^2) (1) \left(\frac{1}{4}\right) d\xi = \frac{1}{3}$$

$$F_3^e = \int_{-1}^1 \frac{1}{2} \xi(\xi + 1) (1) \left(\frac{1}{4}\right) d\xi = \frac{1}{12}$$

Combining these three entries we get

$$F^e = \begin{Bmatrix} 1/12 \\ 1/3 \\ 1/12 \end{Bmatrix}$$

Local to global mapping of the mesh is

$$LtoG = \begin{bmatrix} 1 & 2 & 3 \\ 3 & 4 & 5 \end{bmatrix}$$

Using the assembly rule global system can be obtained as

$$\begin{bmatrix} \frac{19}{6} & -\frac{10}{3} & \frac{1}{6} & 0 & 0 \\ -\frac{22}{3} & \frac{32}{3} & -\frac{10}{3} & 0 & 0 \\ \frac{7}{6} & -\frac{22}{3} & \frac{37}{6} + \frac{19}{6} & -\frac{10}{3} & \frac{1}{6} \\ 0 & 0 & -\frac{22}{3} & \frac{32}{3} & -\frac{10}{3} \\ 0 & 0 & \frac{7}{6} & -\frac{22}{3} & \frac{37}{6} \end{bmatrix} \begin{Bmatrix} T_1 \\ T_2 \\ T_3 \\ T_4 \\ T_5 \end{Bmatrix} = \begin{Bmatrix} \frac{1}{12} \\ \frac{1}{3} \\ \frac{1}{12} + \frac{1}{12} \\ \frac{1}{3} \\ \frac{1}{12} \end{Bmatrix} + \begin{Bmatrix} B_1 \\ 0 \\ 0 \\ 0 \\ B_5 \end{Bmatrix}$$

$T_1 = 0$ is given as an EBC. Applying reduction for the first equation and using $B_5 = -1$ we are left with the following 4x4 system

$$\begin{bmatrix} \frac{32}{3} & -\frac{10}{3} & 0 & 0 \\ -\frac{22}{3} & \frac{56}{6} & -\frac{10}{3} & \frac{1}{6} \\ 0 & -\frac{22}{3} & \frac{32}{3} & -\frac{10}{3} \\ 0 & \frac{7}{6} & -\frac{22}{3} & \frac{37}{6} \end{bmatrix} \begin{Bmatrix} T_2 \\ T_3 \\ T_4 \\ T_5 \end{Bmatrix} = \begin{Bmatrix} 1/3 \\ 1/6 \\ 1/3 \\ 1/12 \end{Bmatrix} + \begin{Bmatrix} 0 \\ 0 \\ 0 \\ -1 \end{Bmatrix}$$

Solving this system we obtain the necessary nodal unknowns as

$$\begin{Bmatrix} T_2 \\ T_3 \\ T_4 \\ T_5 \end{Bmatrix} = \begin{Bmatrix} 0.0591 \\ 0.0890 \\ 0.0648 \\ -0.0884 \end{Bmatrix}$$

The following figure compares the GFEM solution with the approximate solution. The solution obtained at Section 2.11 with 5 linear elements is also given. As seen linear and quadratic solutions provide a comparable performance.

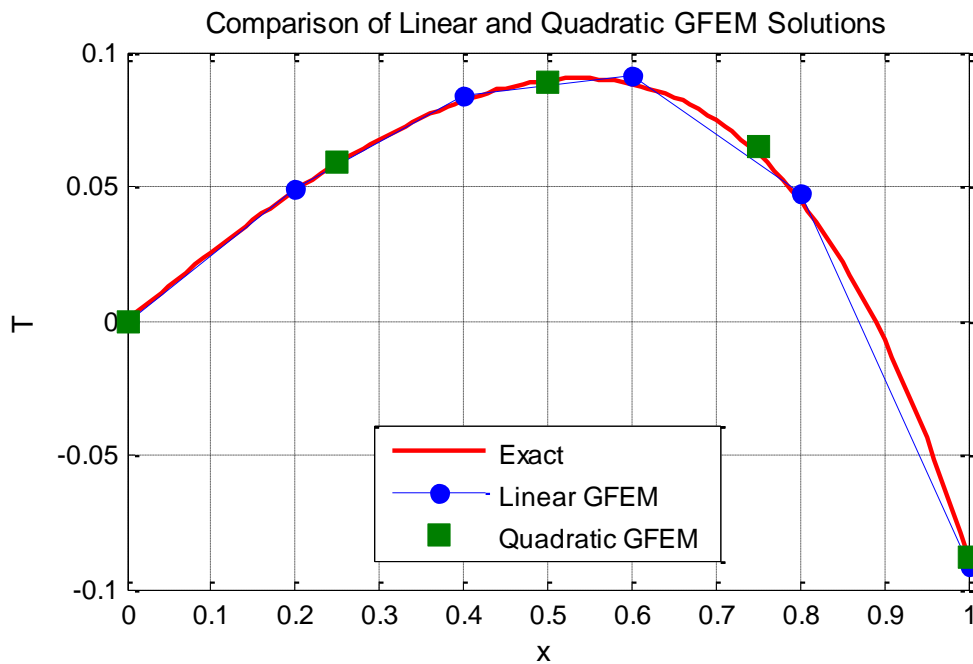

2.15 Fifth 1D Solution

For the last 1D solution consider the following steady, heat transfer problem in a 1D fin with variable circular cross-section.

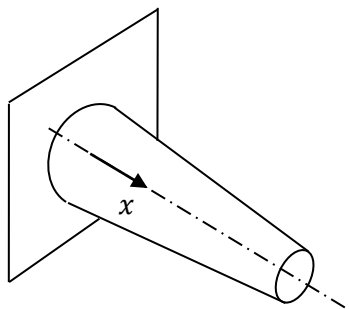

$$\begin{aligned} T_\infty &= 25^\circ\text{C} \quad , \quad h = 100 \text{ W/m}^2\text{K} \\ k &= 140 \text{ W/mK} \\ D_{base} &= 3 \text{ cm} \quad , \quad D_{tip} = D_{base}/2 \\ L &= 6 \text{ cm (fin length)} \end{aligned}$$

$$\begin{aligned} \text{At } x = 0 \quad & T = 100^\circ\text{C} \\ \text{At } x = L \quad & hA_c(T - T_\infty) = -kA_c(dT/dx) \end{aligned}$$

The governing DE is

$$-\frac{d}{dx}\left(kA_c \frac{d\theta}{dx}\right) + hP\theta = 0$$

where $(x) = T(x) - T_\infty$, $A_c(x)$ is the cross-sectional area and $P(x)$ is the perimeter of the fin.

We want to obtain the temperature distribution $\theta(x)$ on the fin using GFEM using a mesh of 4 linear elements of the same length.

Compared to the previous examples we have three main differences

- DE is not AD equation. We need to obtain its weak form.
- $[K^e]$ integrals will be different for each element since A_c and P are functions of x .

Residual of the DE is

$$R(x) = -\frac{d}{dx}\left(kA_c \frac{d\theta}{dx}\right) + hP\theta$$

Weighted residual statement is

$$\int_{\Omega} \left[-\frac{d}{dx}\left(kA_c \frac{d\theta}{dx}\right) + hP\theta \right] w \, dx$$

Apply integration by parts to the first term

$$\int_{\Omega} -\frac{d}{dx}\left(kA_c \frac{d\theta}{dx}\right) w \, dx = \int_{\Omega} \frac{dw}{dx} kA_c \frac{d\theta}{dx} \, dx - \int_{\Gamma} w kA_c \frac{d\theta}{dx} n_x \, d\Gamma$$

Use this in the weighted residual statement to get the following weak form

$$\int_{\Omega} \left(\frac{dw}{dx} kA_c \frac{d\theta}{dx} + hPw\theta \right) \, dx = \int_{\Gamma} w kA_c \frac{d\theta}{dx} n_x \, d\Gamma$$

By looking at the boundary term PV of the problem is θ (temperature) and SV is $kA_c \frac{d\theta}{dx} n_x$ (heat passing through the boundaries).

It is possible to directly write the elemental stiffness matrix and force vector from this equation. We do not need to go through the details that we went for previous solutions. We first need to consider the above weak form to be written for a single element. To get K_{ij}^e formula we use the integral on the left hand side and replace w with S_i and θ with S_j . The result is

$$K_{ij}^e = \int_{\Omega^e} \left(kA_c \frac{dS_i}{dx} \frac{dS_j}{dx} + hPS_i S_j \right) \, dx$$

Since the DE has no terms without the unknown θ elemental force vector is zero for this problem.

In order to be able to use the master element and shape functions defined in terms of the master element coordinate ξ the above K_{ij}^e integral should be converted into the following by introducing the elemental Jacobian J^e

$$K_{ij}^e = \int_{-1}^1 \left(kA_c(x(\xi)) \frac{dS_i}{d\xi} \frac{1}{J} \frac{dS_j}{d\xi} \frac{1}{J} + hP(x(\xi))S_iS_j \right) J d\xi$$

where the Jacobian $J = h^e/2$. Here it is important to note that A_c and P are originally given in terms of x , but in the above integral they need to be written as functions of ξ . To do this we can use the relation between x and ξ coordinates, given by equation (2.21). Since this relation is different for each element, $[K^e]$'s will be different for each element. Further details of the calculation of $[K^e]$'s and their assembly will not be provided here.

Let's also discuss the BC implementation. For a mesh of 4 linear elements there will be a total of NN=5 nodes. After the assembly process we will obtain a 5x5 system in the following form

$$\begin{bmatrix} K_{11} & K_{12} & K_{13} & K_{14} & K_{15} \\ K_{21} & \dots & \dots & \dots & \dots \\ K_{31} & \dots & \dots & \dots & \dots \\ K_{41} & \dots & \dots & \dots & \dots \\ K_{51} & \dots & \dots & \dots & \dots \end{bmatrix} \begin{Bmatrix} \theta_1 \\ \theta_2 \\ \theta_3 \\ \theta_4 \\ \theta_5 \end{Bmatrix} = \begin{Bmatrix} B_1 \\ 0 \\ 0 \\ 0 \\ B_5 \end{Bmatrix}$$

$\theta_1 = 75$ is known due to the given EBC at $x = 0$. Therefore we can reduce the system to a 4x4 system by removing the first equation and first column of the stiffness matrix. But when we do this we need to make changes to the right hand side vector as follows

$$\begin{bmatrix} K_{22} & K_{23} & K_{24} & K_{25} \\ K_{32} & \dots & \dots & \dots \\ K_{42} & \dots & \dots & \dots \\ K_{52} & \dots & \dots & \dots \end{bmatrix} \begin{Bmatrix} \theta_2 \\ \theta_3 \\ \theta_4 \\ \theta_5 \end{Bmatrix} = \begin{Bmatrix} 0 - K_{21}\theta_1 \\ 0 - K_{31}\theta_1 \\ 0 - K_{41}\theta_1 \\ B_5 - K_{51}\theta_1 \end{Bmatrix}$$

The second BC is of mixed type given at node 5 as follows

$$hA_c\theta = -kA_c \frac{dT}{dx}$$

This can be put into the general format of $SV = \alpha PV + \beta$ as follows

$$kA_c \frac{dT}{dx} = -hA_c\theta + 0$$

or with a different notation

$$B_5 = \alpha\theta_5 + \beta$$

where $\alpha = -h(A_c)|_{x=L} = -0.0177$ and $\beta = 0$. We can use these α and β values to modify the global system as follows

$$\begin{bmatrix} K_{22} & K_{23} & K_{24} & K_{25} \\ K_{32} & \dots & \dots & \dots \\ K_{42} & \dots & \dots & \dots \\ K_{52} & \dots & \dots & K_{55} - (-0.0177) \end{bmatrix} \begin{Bmatrix} \theta_2 \\ \theta_3 \\ \theta_4 \\ \theta_5 \end{Bmatrix} = \begin{Bmatrix} -K_{21}\theta_1 \\ -K_{31}\theta_1 \\ -K_{41}\theta_1 \\ 0 - K_{51}\theta_1 \end{Bmatrix}$$

Now we can solve the system to obtain 4 unknown temperatures as follows

$$\begin{Bmatrix} \theta_2 \\ \theta_3 \\ \theta_4 \\ \theta_5 \end{Bmatrix} = \begin{Bmatrix} 70.68 \\ 66.94 \\ 64.00 \\ 62.33 \end{Bmatrix} \text{ } ^\circ\text{C}$$

FE solution is plotted below.

GFEM solution of the variable area fin conduction problem with 4 linear elements

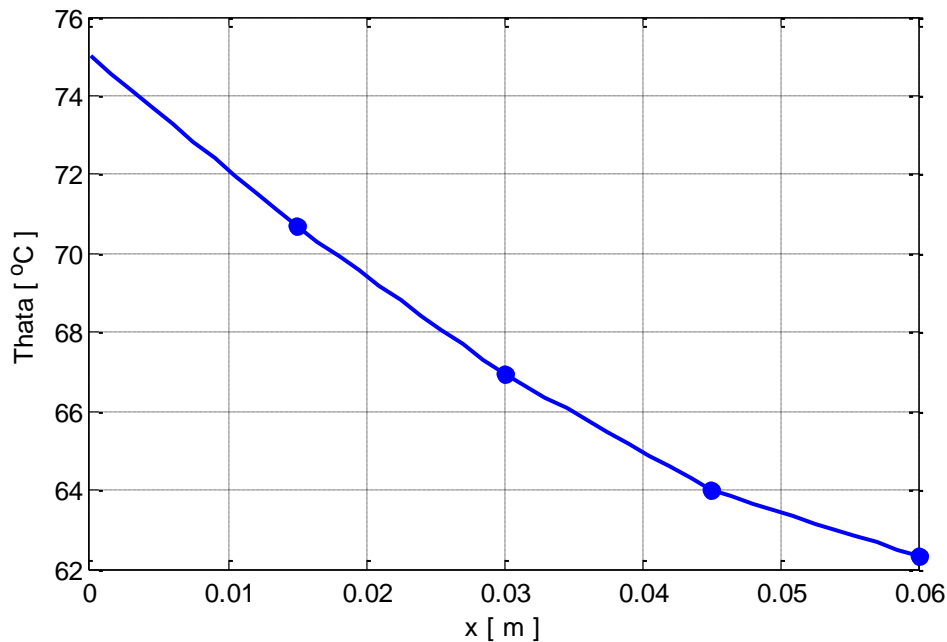

As a post processing calculation the amount of heat that goes through the fin base, which is important in evaluating the fin's performance, can be evaluated. The value we want is

$$Q_{base} = \left(kA_c \frac{d\theta}{dx} n_x \right)_{x=0}$$

where $n_x = -1$ at the left boundary of the domain. Q_{base} can be calculated in two different ways. First one is to use the first equation of the original 5x5 system that we had before performing reduction for the EBC. Substituting the already calculated temperature values we can obtain B_1 which is equal to Q_{base} .

In an alternative way we can use the calculated nodal temperatures to determine the slope of temperature at the fin base and use it to calculate the required heat value. Over the first element the temperature varies linearly as seen above and the slope of this linear variation at $x = 0$ is

$$\left. \frac{d\theta^{e=1}}{dx} \right|_{at \ x=0} = \frac{\theta_2 - \theta_1}{h^e} = \frac{70.68 - 75}{0.015}$$

Multiplying this slope with $k(A_c)_{x=0}$ will give the required heat value as follows

$$Q_{base} = \left(kA_c \frac{d\theta}{dx} n_x \right)_{x=0} = (140) \left(\frac{\pi \cdot 0.03^2}{4} \right) \left(\frac{70.68 - 75}{0.015} \right) (-1) = 28.4 \text{ Watt}$$

which is a positive value, showing that heat is coming into the problem domain at the wall. With the use of n_x as a part of the SV, in a heat transfer problem, a positive SV value always corresponds to "heat coming in", both at the left boundary and at the right boundary.

Note that the two alternative post processing calculation methods discussed above will give slightly different results (calculate Q_{base} using the first method and see), especially on coarse meshes. Although the first one is usually more accurate, due to practical reasons we usually prefer the second one.

2.16 Exercises

E-2.1. For the solution of 1D problems that we studied in this chapter Finite Difference Method (FDM) is also a powerful and easy to use numerical technique [1]. Solve the problem given at Section 2.11 using FDM with 6 nodes. Discretize the DE by approximating the first and second order derivatives at a node n using second order accurate central differencing as follows

$$\frac{dT_n}{dx} = \frac{T_{n+1} - T_{n-1}}{2\Delta x}, \quad \frac{d^2T_n}{dx^2} = \frac{T_{n+1} - 2T_n + T_{n-1}}{(\Delta x)^2}$$

where Δx is the distance between equi-spaced nodes, which is equal to h^e . Implement the EBC at the left boundary in the same way as we did for FEM. For the NBC at the right boundary use second order accurate backward difference versions of the above equations (You can find them in a numerical methods book such as [1]).

Obtain the nodal temperature values and compare the FDM solution with the exact solution and the FEM solution.

E-2.2. Solve the problem of Section 2.11 with 10 linear elements and compare the solution with the original 5 element one and with the exact solution. Do NOT repeat unnecessary calculations that are already given in Section 2.11.

E-2.3. At Section 2.14 we performed a FE solution using 2 quadratic elements and the solution is plotted using squares without any lines between them. Actually over each element the solution is a second order polynomial. Without the curves joining the points it is NOT possible to see the C^0 continuous nature of the solution and one common misunderstanding about using quadratic elements is that they provide C^1 continuous solutions. To show that this is NOT the case obtain the approximate solution over each element as second order polynomials using the elemental version of equation (2.8) given below

$$T^e = \sum_{j=1}^3 S_j T_j^e = S_1 T_1^e + S_2 T_2^e + S_3 T_3^e$$

where S_j 's are shape functions given in equation (2.28) and T_j^e 's are the calculated nodal unknown values. The above equation will provide the necessary second order polynomials, but in terms of ξ . To convert them into polynomials in terms of x use equation (2.21) which is not only valid for linear but also for quadratic elements.

Find the polynomial approximate solutions over the two elements. Calculate their slopes at the interface of the elements and show that the slopes are not equal.

E-2.4. Integration by parts (IBP) brings two important features to the FE formulation. First the differentiation order of the unknown reduces allowing for the use of C^0 continuous approximations. Second the SV of the problem is introduced into the formulation in the boundary integral term, which can be used to implement Natural and mixed BCs.

But what happens if we do not use IBP? Obtain the elemental stiffness matrix integral K_{ij}^e equation (similar to equation (2.18)) when IBP is not applied.

Repeat the solution given in Section 2.10 with this new formulation. What problems did you face with, if there are any.

Repeat the solution given in Section 2.14 with this new formulation. What problems did you face with, if there are any.

E-2.5. A plane wall is a composite of two materials, A and B. The wall of material A has a uniform heat generation $\dot{q} = 1.5 \times 10^6 \text{ W/m}^3$, $k_A = 75 \text{ W/(mK)}$ and thickness $L_A = 50 \text{ mm}$. The wall material B has no generation with $k_B = 150 \text{ W/(mK)}$ and thickness $L_B = 20 \text{ mm}$. The inner surface of material A is well insulated, while the outer surface of material B is cooled by a water stream with $T_\infty = 30 \text{ }^\circ\text{C}$ and $h = 1000 \text{ W/(m}^2\text{K)}$.

a) Perform a FE solution using 5 linear elements in material A and 2 linear elements in material B, i.e. all elements will have the same length of 10 mm. Provide the calculated nodal unknowns and plot the FE solution. To check your solution, temperature at $x = 0$ is given as $140 \text{ }^\circ\text{C}$ in the reference [2].

b) Compare the generated heat with the one removed by convection.

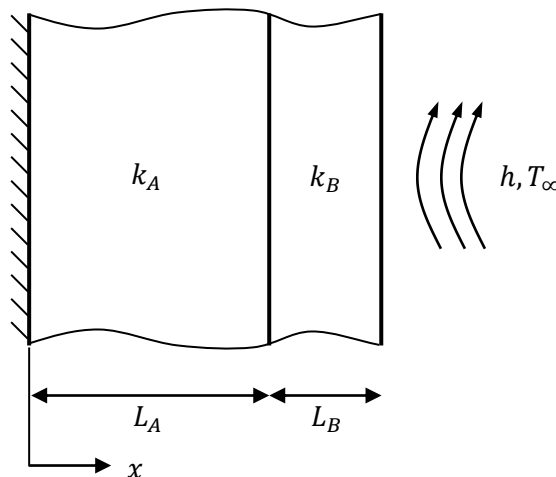

E-2.6. The solution given at Section 2.15 is incomplete. Perform the missing calculations and obtain the final result.

E-2.7. A mild steel steam pipe has an outside diameter of 15 cm and a wall thickness of 0.7 cm. It is insulated with a 5.3 cm-thick layer of 85 % magnesia insulation. Superheated steam at $T_s = 500$ K flows through the pipe with an inside heat transfer coefficient of $h_i = 35$ W/(m²K). Heat is lost by convection to surroundings at $T_\infty = 300$ K with an outside heat transfer coefficient of $h_o = 8$ W/(m²K). Conductivities at an average temperature of 400 K are $k_{steel} = 54$ W/(mK) and $k_{magnesia} = 0.073$ W/(mK).

a) Compute the 1D temperature distribution between 0.068 m $< r < 0.128$ m. Use 1 element over the steel pipe and 3 equi-length elements over the insulation.

b) Calculate the amount of heat loss for a 20 m length pipe. To check your solution, this value is given as 2880 W in the reference [3].

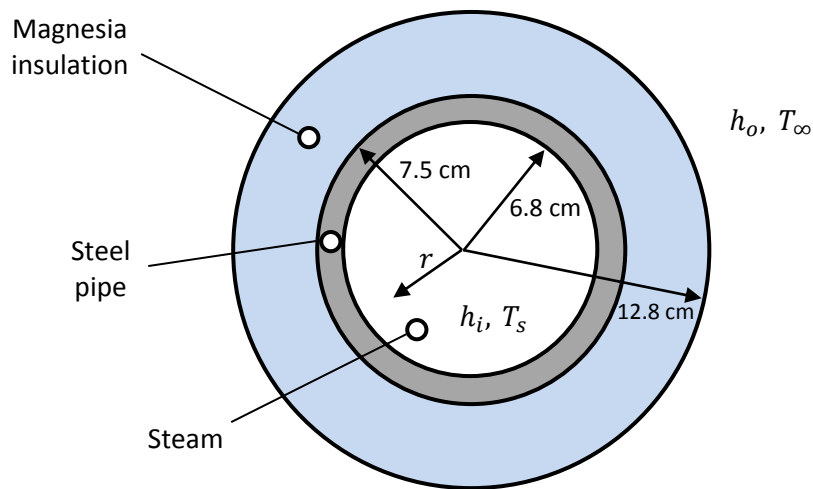

References

- [1] S. C. Chapra, R. P. Canale, Numerical Methods for Engineers, 5th ed., Mc Graw-Hill, 2006.
- [2] F. P. Incropera, D. P. Dewitt, T. L. Bergman, A. S. Lavine, Fundamentals of Heat and Mass Transfer, 6th ed., John Wiley and Sons, 2007.
- [3] A. F. Mills, Heat Transfer, 2nd ed., Prentice Hall, 1999.