



cover picture  
<http://mytravelphotos.net/wp-content/uploads/2013/03/Torre-Agbar-Floures-1-3.jpg>

## Torre Agbar

### Information

Official name: Torre Agbar (1)  
Alternative name: Torre Agbar de Barcelona (1)  
Location: Barcelona, Spain, 41°24'13"N 2°11'22"E (1)  
Building function: commercial office (1)  
Architectural height: 144.4m top floor 129.30m (1)  
Number of stories: 33 above ground, 4 below ground (1)  
Status: Completed (2001 to 2004) (1)  
2004 (1)  
Completion: 2004 (1)  
Architects: Jean Nouvel and b720 Architects (Barcelona) (1)  
Structural Engineer: CBGM, Moysi Asociats, Robert Vila y Reixac (2)  
Structural system: Framed tube (1)  
Reinforced concrete C30 (3)  
Floor plan measurements: Length: 39,40 m Width: 35,42 m (4&5)  
Tower GFA: 51.486m<sup>2</sup> (2)  
Architectural style: Modernism (1)  
Awards: Emporis Skyscraper Award Year 2004 (2nd place)  
Best tallest building in Barcelona



1.BMPORS  
2.CTBUH  
3.FRAMMEBAR barcelo,SA  
4.CBGM Moysi Asociats  
5.José Ramón Solé Marzo  
IMAGE: [http://upload.wikimedia.org/wikipedia/commons/4/46/Torre\\_Agbar\\_-\\_Barcelona%2C\\_Spain\\_-\\_Jan\\_2007.jpg](http://upload.wikimedia.org/wikipedia/commons/4/46/Torre_Agbar_-_Barcelona%2C_Spain_-_Jan_2007.jpg)

### Inspiration



"The Tower might be a distant echo of 610 Catalan obsessions, carried on the winds that blow in from Montserrat". Jean Nouvel

Inspired by the architectural legacy left behind by Gaudí and the hills of Montserrat, the Agbar Tower rises from the ground with the power and lightness of a geyser, touching the blue skies of Barcelona. (5)

5 <http://www.torreagbar.com/home.asp>

### Program

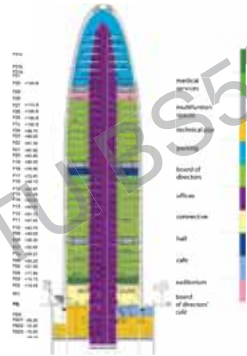

Source: Jean Nouvel

### Floor plan

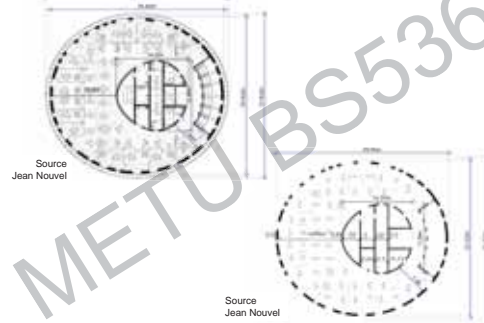

Source: Jean Nouvel

Source: Jean Nouvel

### Inner tube

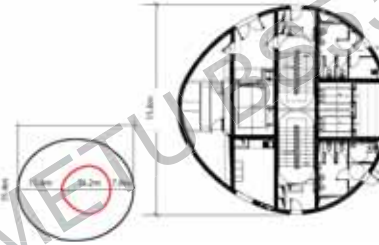

Source: Jean Nouvel

### Wall thickness

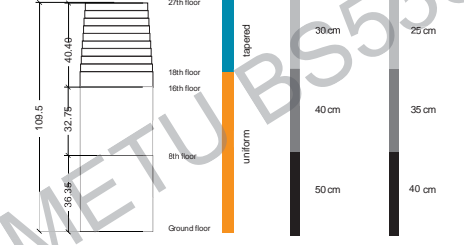

Source: Crespo Cabillo

### Windows pattern

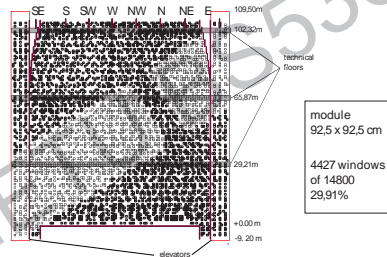

Source: Jean Nouvel

### 26<sup>th</sup> floor and below floor construction

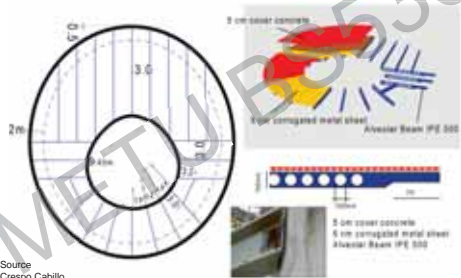

Source: Crespo Cabillo

### Dome design

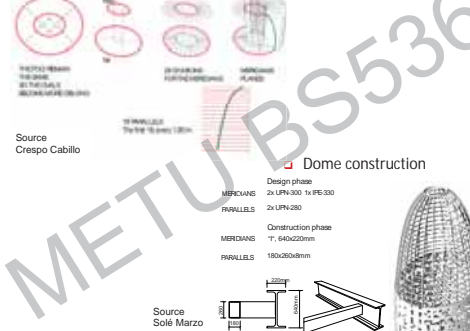

### Dome construction

### 27<sup>th</sup> floor and above.

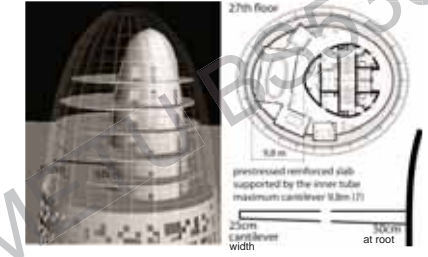

### Axonometry

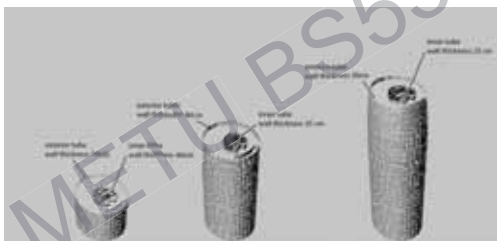

drawn by Arch. Ir. J.I. Zaratiegui

### Axonometry

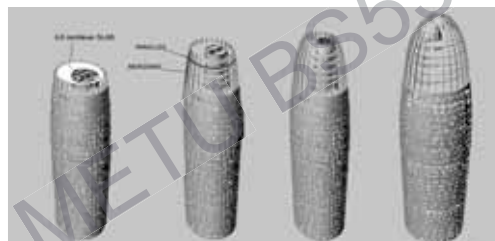

drawn by Arch. Ir. J.I. Zaratiegui

### Sources

- 1 BMPORS Emporis GmbH is a real estate data mining company with headquarters in Hamburg, Germany. The company collects and publishes data and photographs of buildings worldwide. (Wikipedia) <http://www.emporis.com/building/torreagbar-barcelona-spain>
- 2 CTBUH The Council on Tall Buildings and Urban Habitat is an international body in the field of tall buildings and sustainable urban design. (Wikipedia) <http://skyscrapercenter.com/barcelona/torre-agbar/>
- 3 Putzmeister Ibérica, S.A.: For over 30 years Putzmeister has been designing concrete spraying equipment for mines and tunnels. Their Putzmeister MX 28-Z was used during the construction of Torre Agbar [http://www.constantia.ro/nr1/web/tematicos\\_resultado.asp?id=132](http://www.constantia.ro/nr1/web/tematicos_resultado.asp?id=132)
- 4 Jean Nouvel Atelier: Architect of the project [www.aavn.fr/AVN/download/Ar\\_ea\\_nouvel-barcelona2-ind.pdf](http://www.aavn.fr/AVN/download/Ar_ea_nouvel-barcelona2-ind.pdf)
- 5 José Ramón Solé Marzo: BOMA's Director for Levante area. BOMA INFASA, former BOMA SL, is the firm responsible of the structure Proyecto y ejecución de la estructura de la Torre Agbar (Project and execution of the structure of Torre Agbar), BOMAINPASA (former BOMAS), engineer firm for the structure.
- 6 Crespo Cabillo, Isabel: Professor at Universitat Politècnica de Catalunya. Control gráfico de formas y superficies de transición. Font, J. (director/a). PhD Thesis Universitat Politècnica de Catalunya, Departament d'Expressió Gràfica Arquitectònica I, 2005.